

INDUSTRIAL

TD210GNBT 24'
TD210PHBT 24'
TD220PHBT 26'
TD220PHTILT 30'

The Industrial series trailers are engineered using the optimal steel frame to maximize strength, durability, and payload capacity. Each trailer features tandem axles, starting at 10,000 lb. and ranging up to 20,000 lb. per axle. Electric brakes are standard on trailers with 10,000 lb. axles, while trailers with tandem 20,000 lb. axles are offered with a complete air braking system. Complying with Canadian Motor Vehicle Safety Standards, this system includes auto slack adjusters, spring brakes and an antilock braking system.

A leader in the industry, the Industrial series is known for its toughness and ability to handle your tracked loader, backhoe or whatever equipment your job site requires. Models are available with pintle, gooseneck or fifth-wheel hitches to match all of your needs.

Now you can safely load tracked equipment without having to worry about a rear impact guard.



Strong & Dependable



Trailtech Inc.

Box 988, Gravelbourg, SK, Canada S0H 1X0
P: (306) 648-3158 | F: (306) 648-3305

 **TRAILTECH**
www.trailtech.com

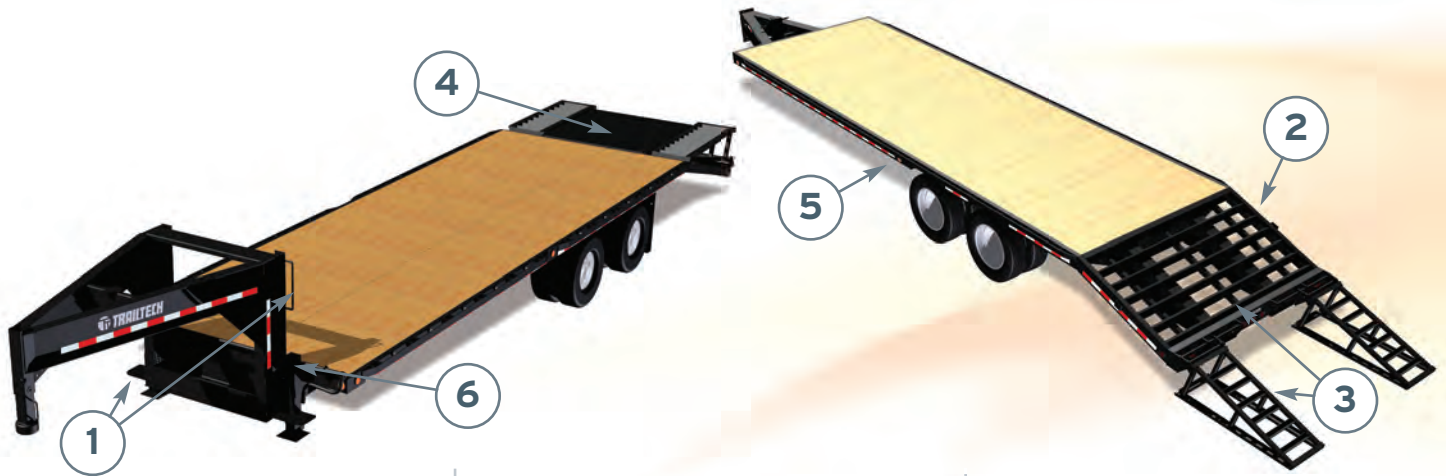

1) Steps & Grab Handles

Gooseneck step and grab handles make it easier and safer to get up on to the trailer deck.



2) Open Cleated Beavertail

The Open Cleated Beavertail eliminates the slippage common on wooden beavertails.



3) Beavertail & Double Pivot Ramps

The 5' Beavertail creates an ideal loading incline combined with the ease of spring assisted ramps.



4) Spring Assisted Flip Up Center

It is now easier than ever to extend the length of your deck with the spring assisted flip up centre.



5) LED Lighting

LED lighting, which allows for faster response time and brighter lights for safety, is standard on all models.



6) Dual Drop Foot Jacks

Dual HD Drop Foot Jacks and Expanded Metal Basket are standard on all Goosenecks, for increased stability, lift and storage capacity.

Features	TD210GNBT 24'	TD210PHBT 24'	TD220PHBT 26'	TD220PHTILT 30'
Main Frame	10" I-beam	10" I-beam	12" I-beam	12" I-beam
Crossmembers	3 x 2 x .125	3 x 2 x .125	4" I-beam	4" I-beam
Axles	(2) 10,000 lb Dual Electric Braking	(2) 10,000 lb Dual Electric Braking	(2) 20,000 lb Dual Air Braking (w/ABS)	(2) 20,000 lb Dual Air Braking (w/ABS)
Hitch	Gooseneck 2 5/16" Ball Coupler	Adjustable Lunette Eye	Adjustable Lunette Eye	Adjustable Lunette Eye
Jack	Double	Single	Two Speed	Two Speed Landing Gear
Deck Height	37"	37"	41"	41"
Beavertail c/w Double Pivot Ramps	Standard Spring Assisted Flip Up Center	Standard	Standard	Hinged Beavertail Only
Tires	ST235/80R16 Radial	ST235/80R16 Radial	255/70R22.5 Radial	255/70R22.5 Radial
Options	Gooseneck King Pin	Spring Assisted Flip Up Center, 2 Speed Jack/Expanded Metal in Hitch	-	-
Curb Weight	5930 lb	5534 lb	9127 lb	13,000 lb

* All models have the following standard features: LED Lights, Rub rail w/stake pockets, 102" Overall width.